

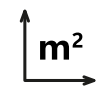







NEW 3 X 3M PORTABLE BUILDING
BLACK FRAME - SPTU220029 | BRAND NEW

Purchase Price - \$24,750 + GST
Pricing excludes delivery - quoted on request

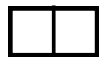
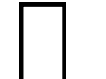

Building Inclusions:

-  9 sqm (3m x 3m)
-  1x 2200mm double-glazed ranch slider door
-  1x 1500mm double-glazed double awning window
-  Corten steel, zinc galvanised, two pac paint finished exterior painted in Grey Friars
-  Internal walls are lined in birch ply, ceiling is lined with acoustic panels for sound proofing
-  Grey carpet tiles
-  Insulated with fire retardant rock wall (72 mm walls, 100mm floor and ceiling)
-  5x 10-amp standard twin power outlets, external C-Form 32amp connection, switchboard
-  2x black 60 W LED wall lights, 1x exterior security light

Introducing our newest high-spec transportable sleepout or home office. At 9sqm, it is perfectly sized to comfortably fit a queen-sized bed and drawers, or to arrange as a versatile office space.

Fully insulated to ensure warmth in winter and coolness in summer, it features ply wall panels for a stylish and durable interior finish, and acoustic panels on the roof to provide added comfort and noise reduction. Soft LED lights create a pleasant and efficient lighting environment, while double-glazed windows enhance thermal efficiency and sound insulation.

Exterior security lighting adds an extra layer of safety and convenience. Ideal for those needing extra space for guests, a quiet home office, or a personal retreat.

Additional inclusions:

- Electrical WOF - 4 years, issued prior to delivery.
- Sales multi-part new building warranty included with this building

Exclusions:

Delivery and installation, adaptations, site or groundworks, and joining kit if connecting buildings. Please enquire for a quote.

Pre-purchase inspection:

We encourage inspections of all our buildings before lease or purchase, please call us to make an appointment.

**NEW 3 X 3M PORTABLE BUILDING
BLACK FRAME - SPTU220029 | BRAND NEW**

Purchase Price - \$27,500 + GST







Hire Price - please enquire

Pricing excludes delivery - quoted on request

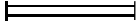

Images below for illustrative purposes - the building does not include furniture



-  DOUBLE POWER POINT
(300MM ABOVE FLOOR LEVEL
UNLESS OTHERWISE STATED)
-  LIGHT SWITCH
-  LED STRIP LIGHT
-  300MM CIRCULAR LED CEILING LIGHT
(IP65 IN BATHROOM AREA)
-  MAIN SWITCHBOARD
-  32A CEE 3P CONNECTION
-  EXTERNAL LIGHTING

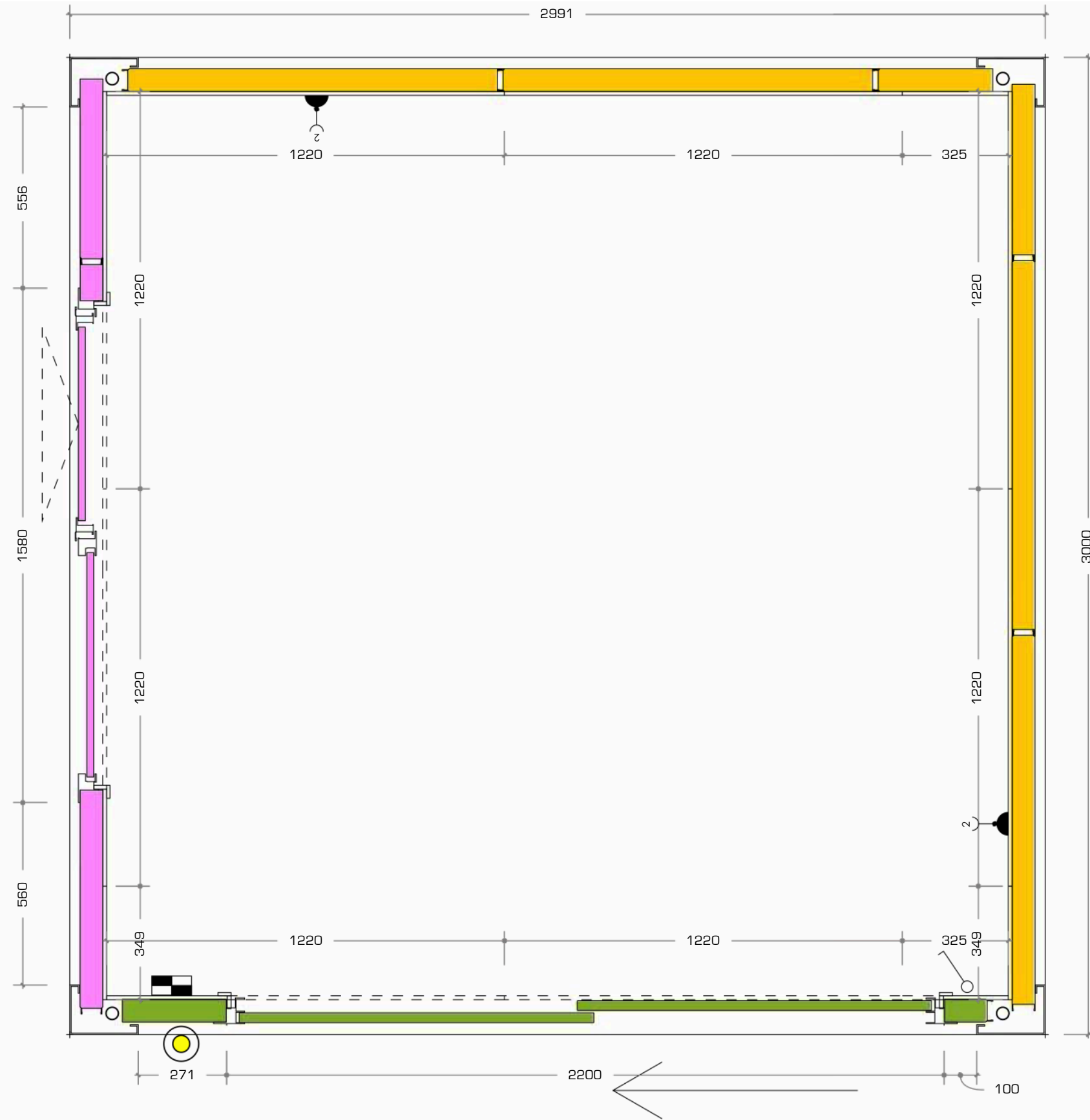

1 FLOOR PLAN
1:15 at A3



1 FRONT ELEVATION
1:30 at A3

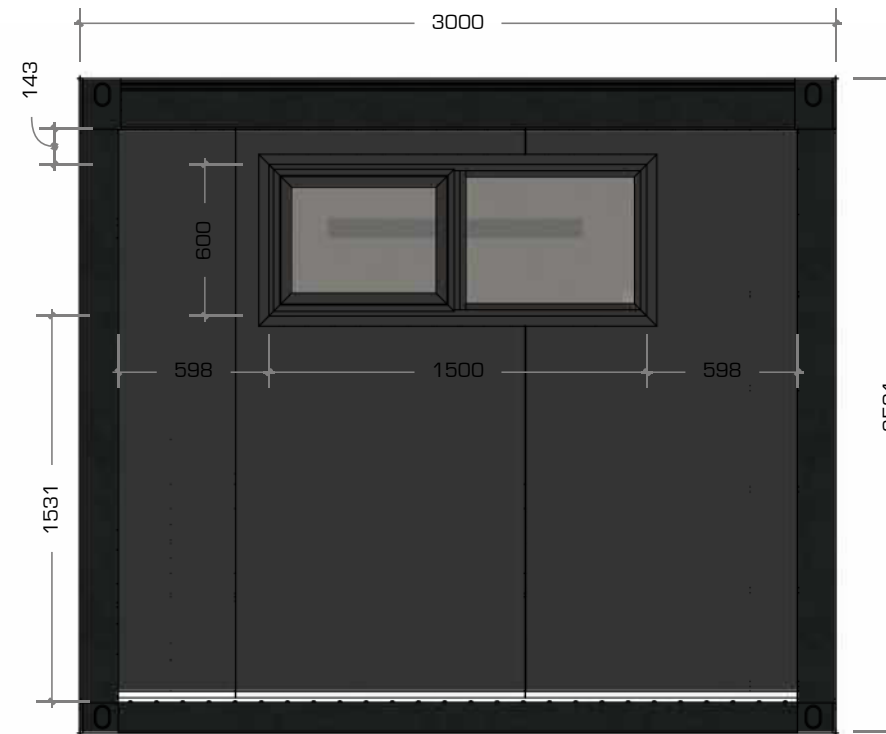

2 LHS ELEVATION
1:30 at A3

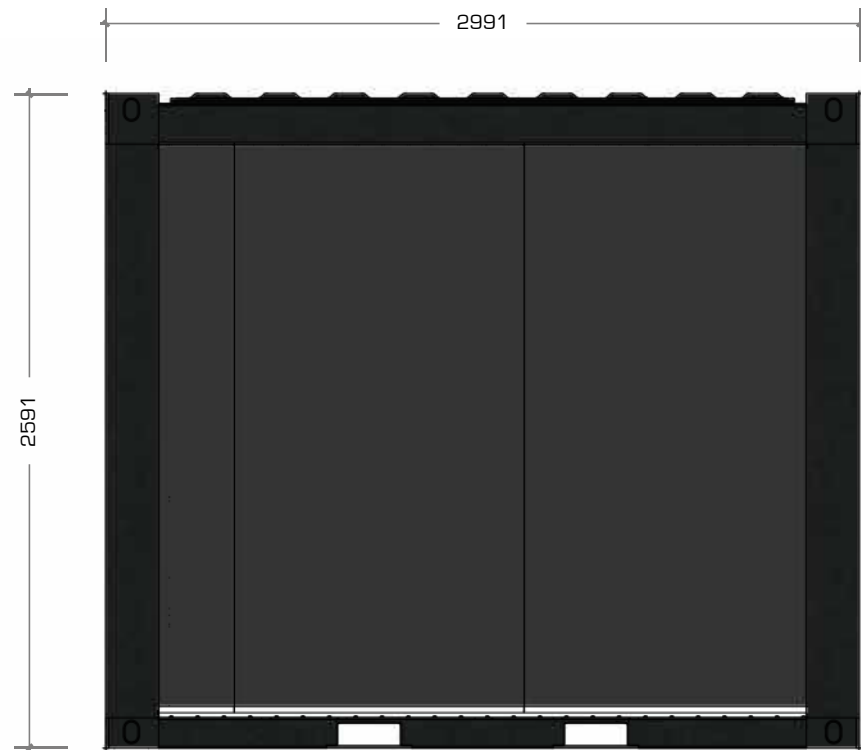

3 BACK ELEVATION
1:30 at A3

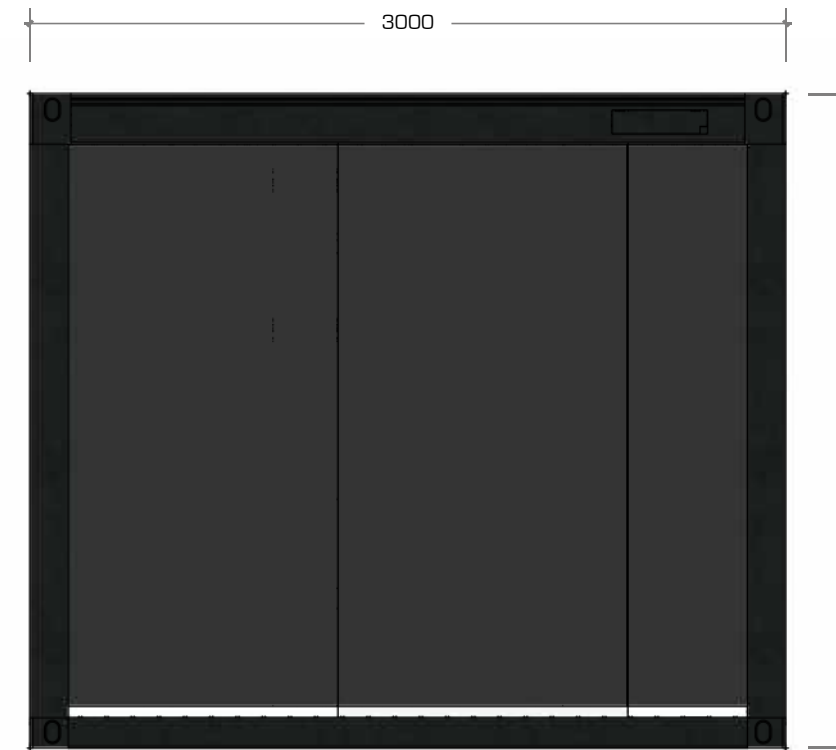

4 RHS ELEVATION
1:30 at A3

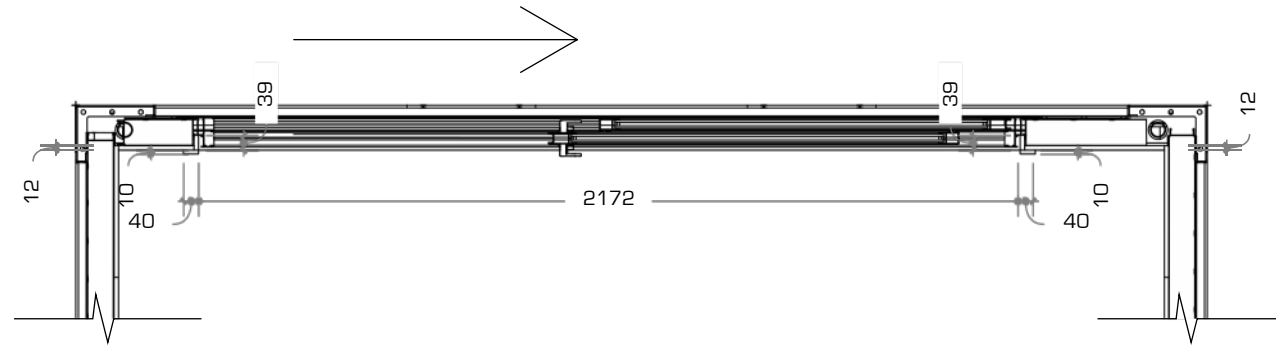

2 FRONT WALL - SECTION
1:20 at A3

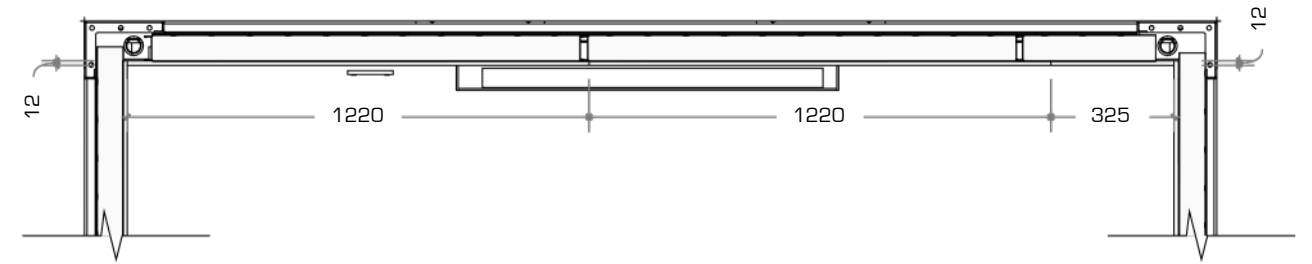

4 BACK WALL - SECTION
1:20 at A3

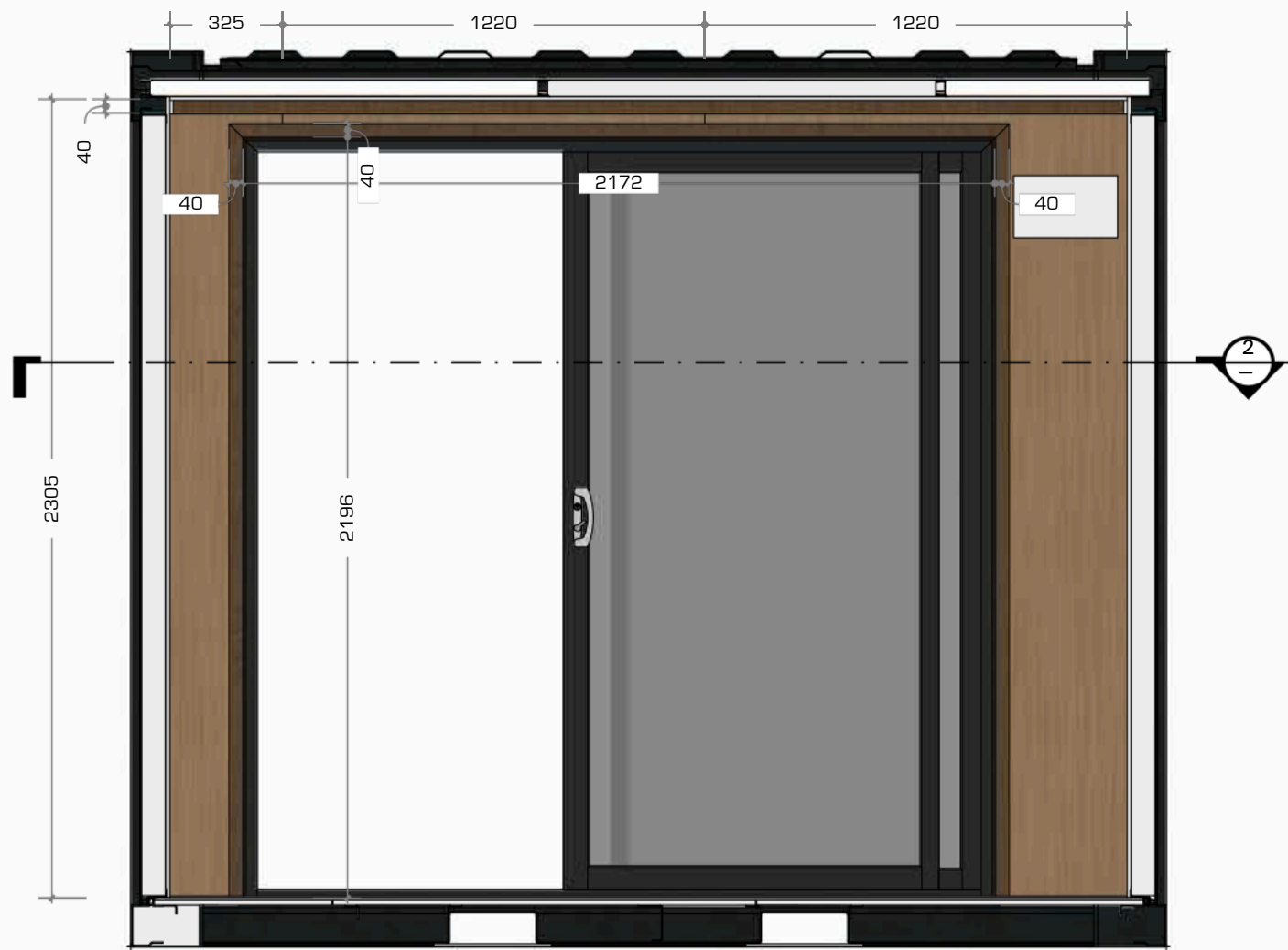

1 FRONT WALL - INTERNAL
1:20 at A3

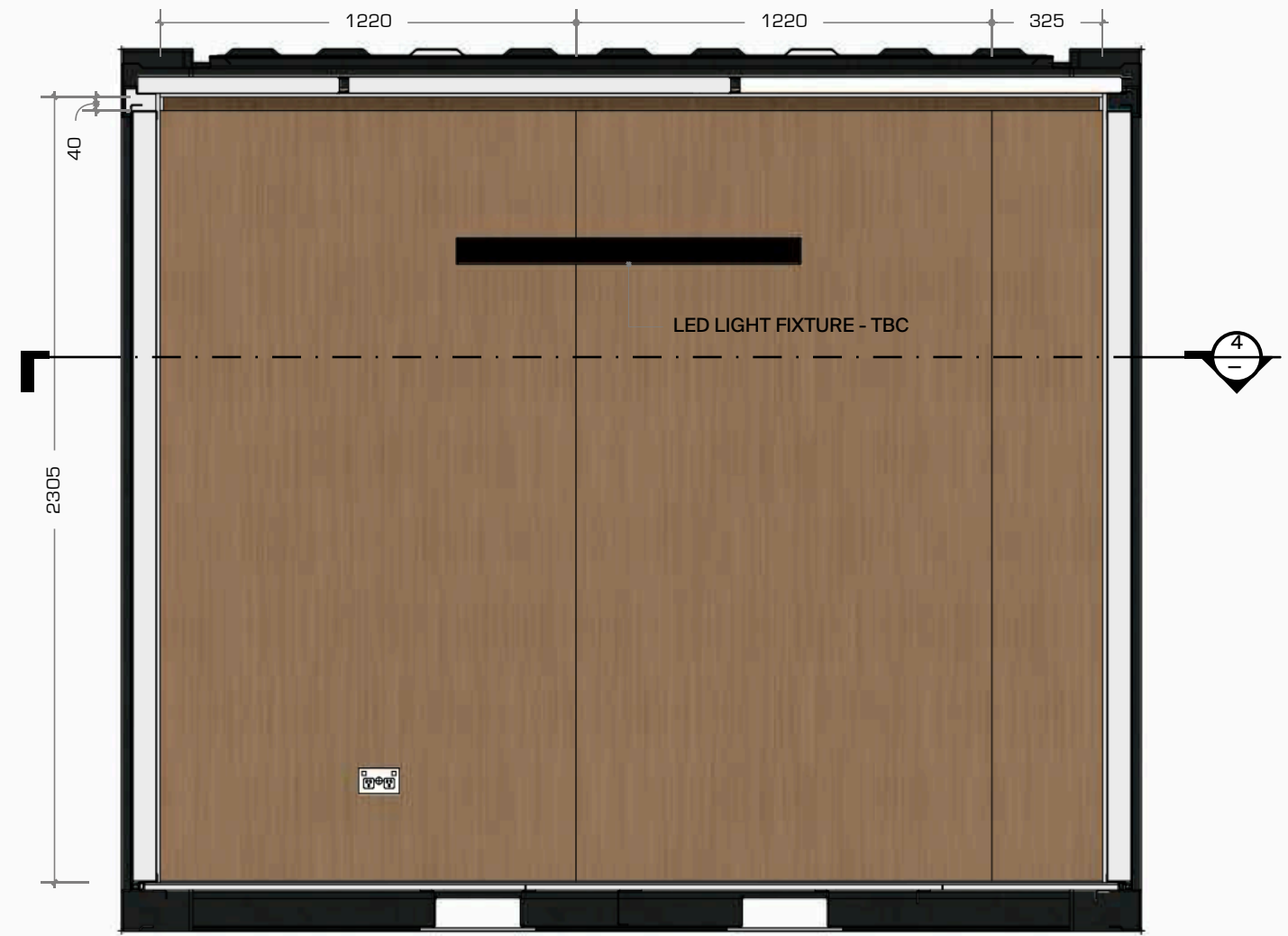

3 BACK WALL - INTERNAL
1:20 at A3

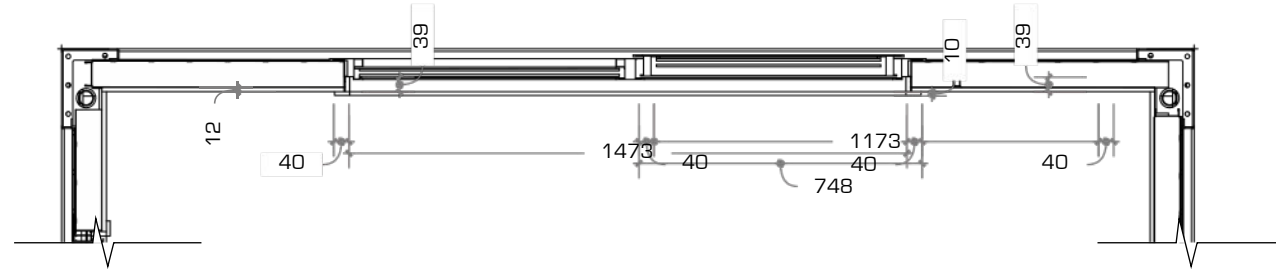

2 LHS WALL - SECTION
1:20 at A3

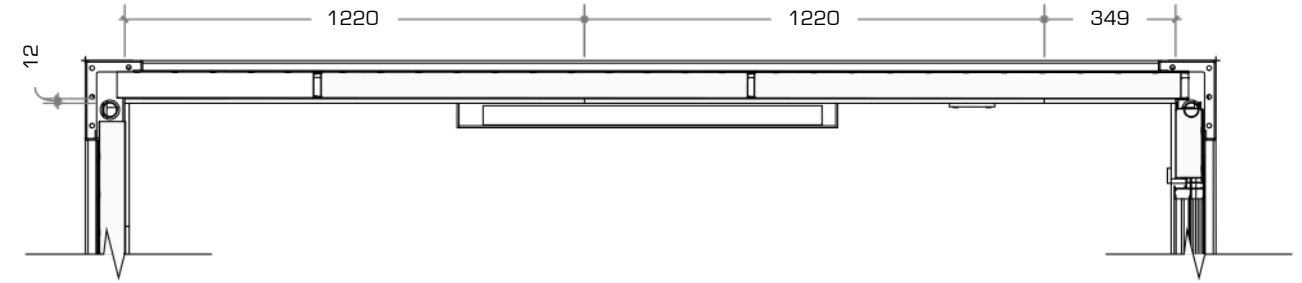

4 RHS WALL - SECTION
1:20 at A3

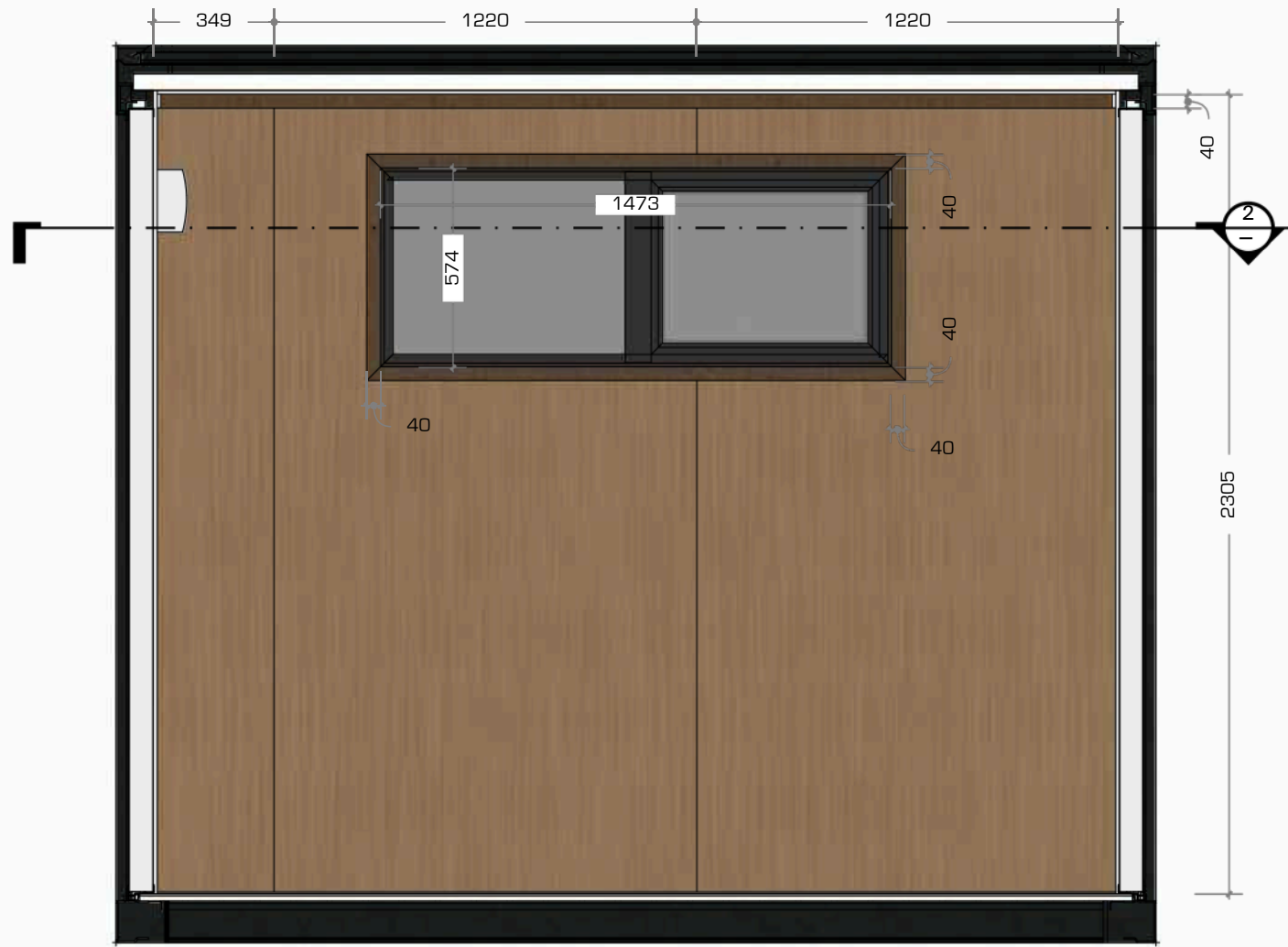

1 LHS WALL - INTERNAL
1:20 at A3

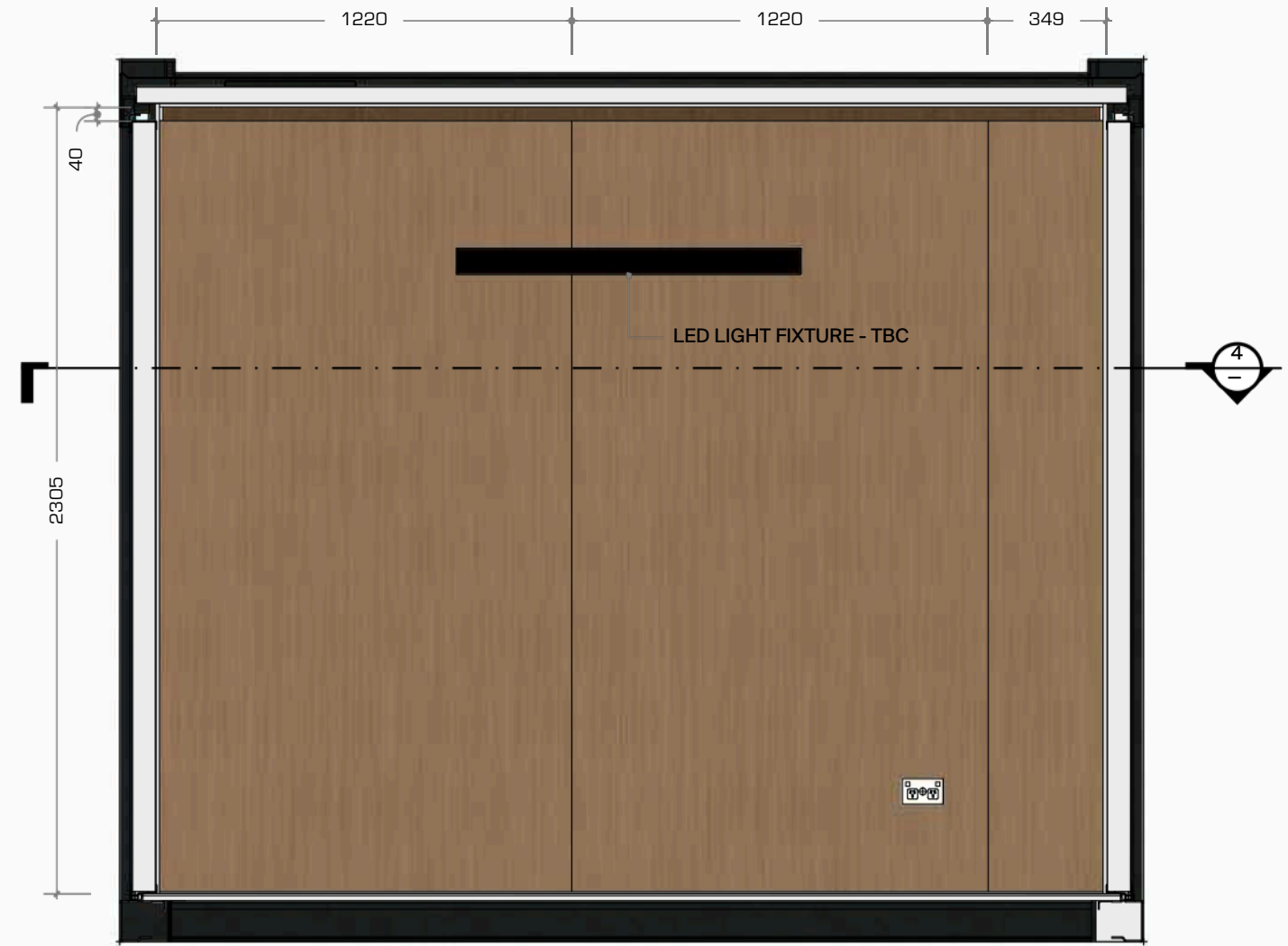

3 RHS WALL - INTERNAL
1:20 at A3

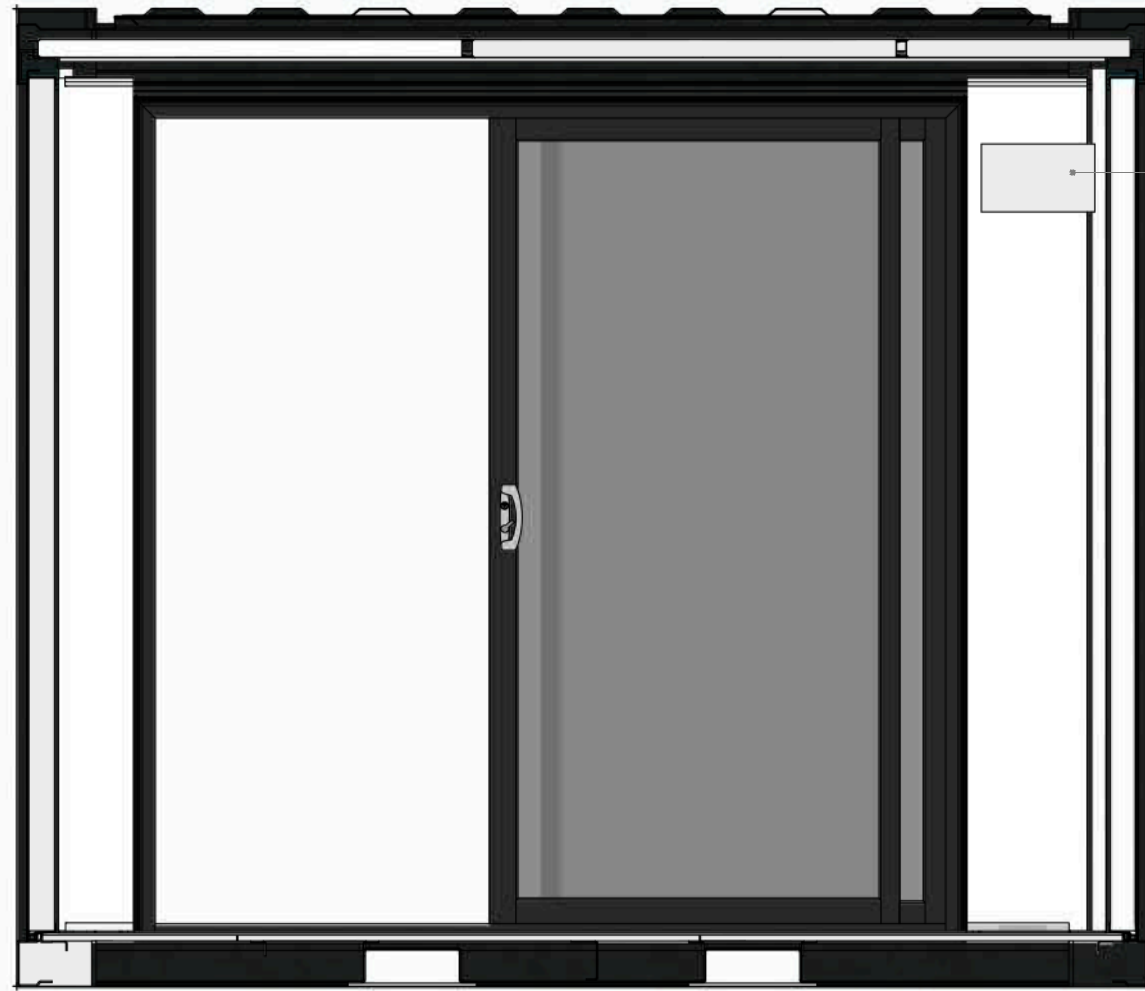

DB CENTRED
IN WALL PANEL
CTR 1995MM FROM FFL

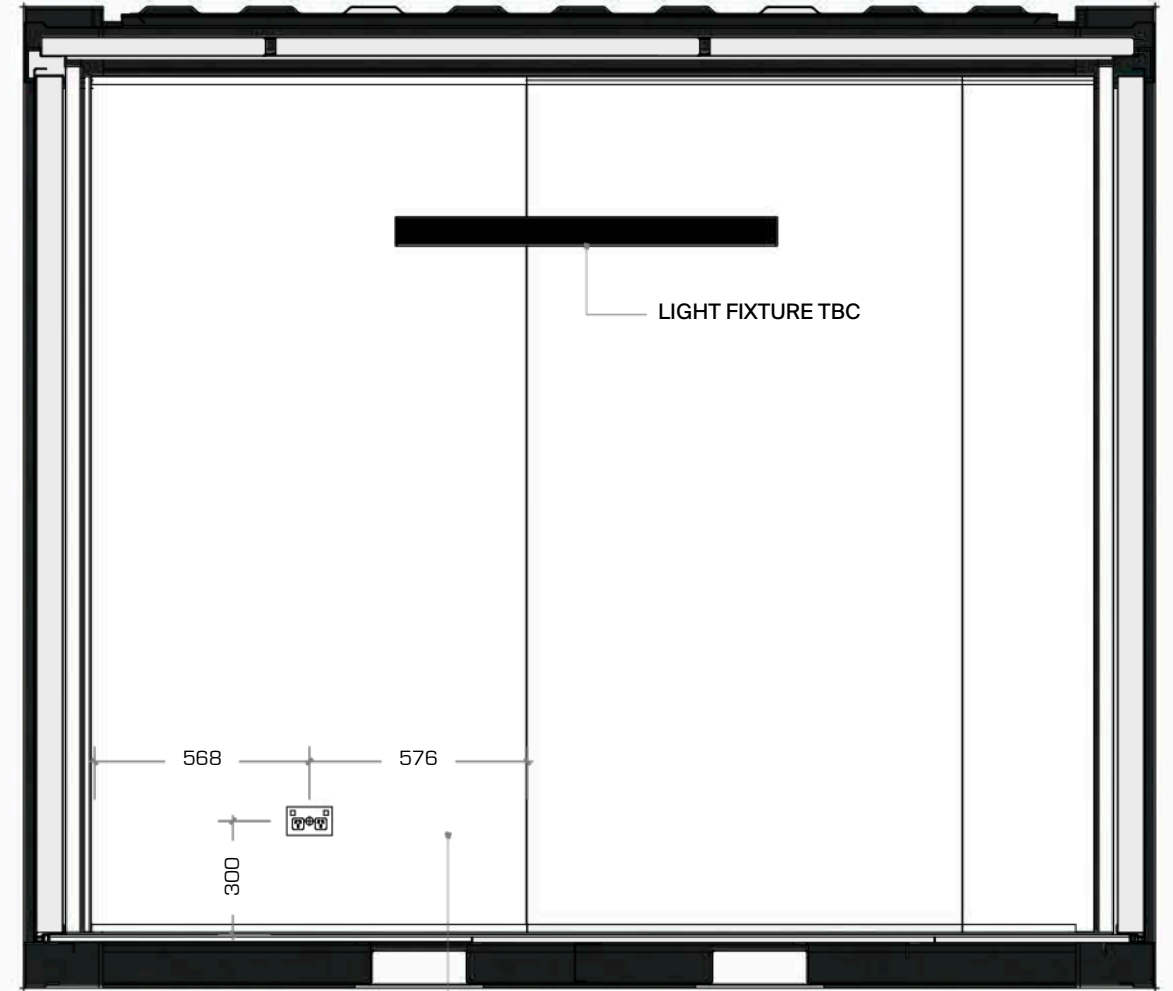

LIGHT FIXTURE TBC

568 576
300

STANDARD WALL PANEL WITH POWER POINT

1 FRONT WALL - INTERNAL
1:20 at A3

3 BACK WALL - INTERNAL
1:20 at A3

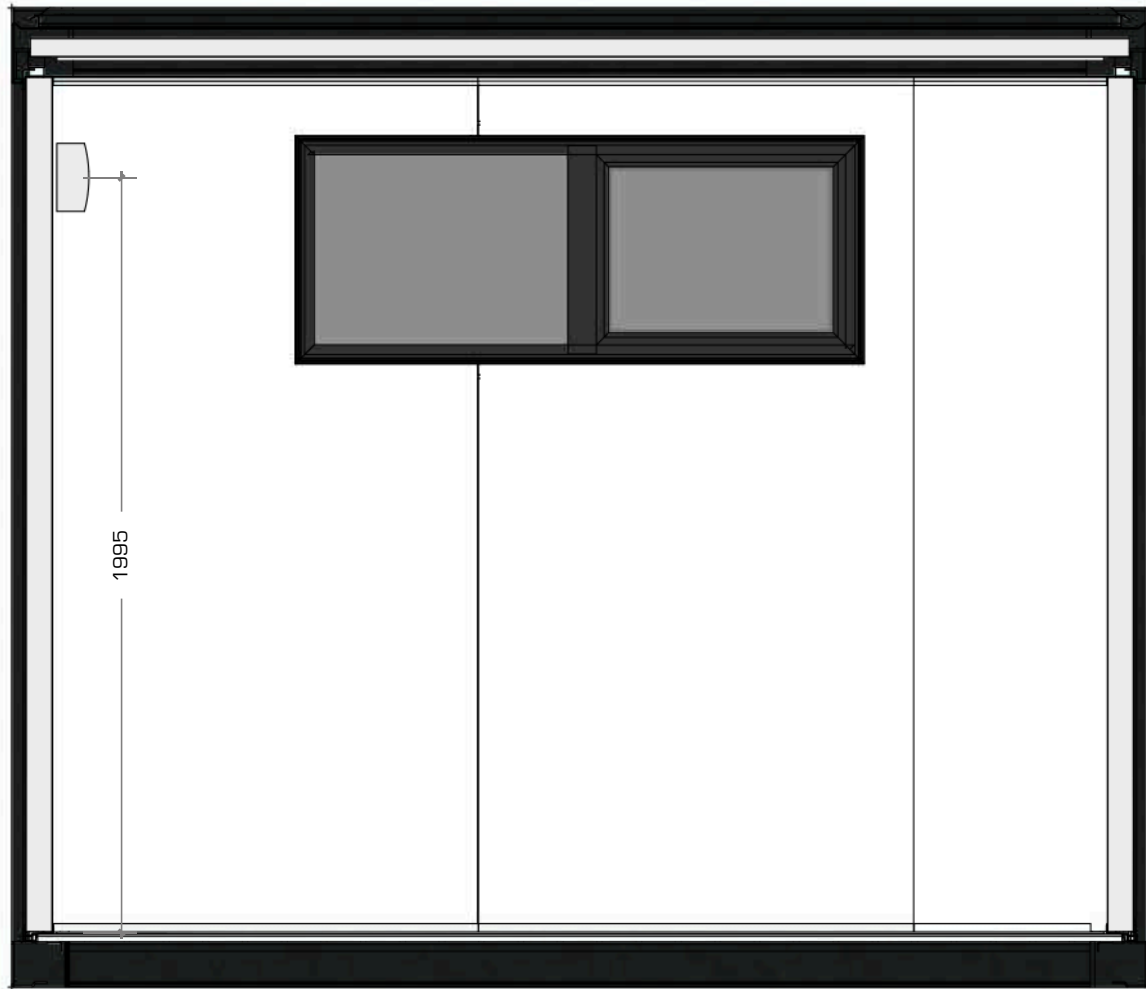

1 LHS WALL - INTERNAL
1:20 at A3

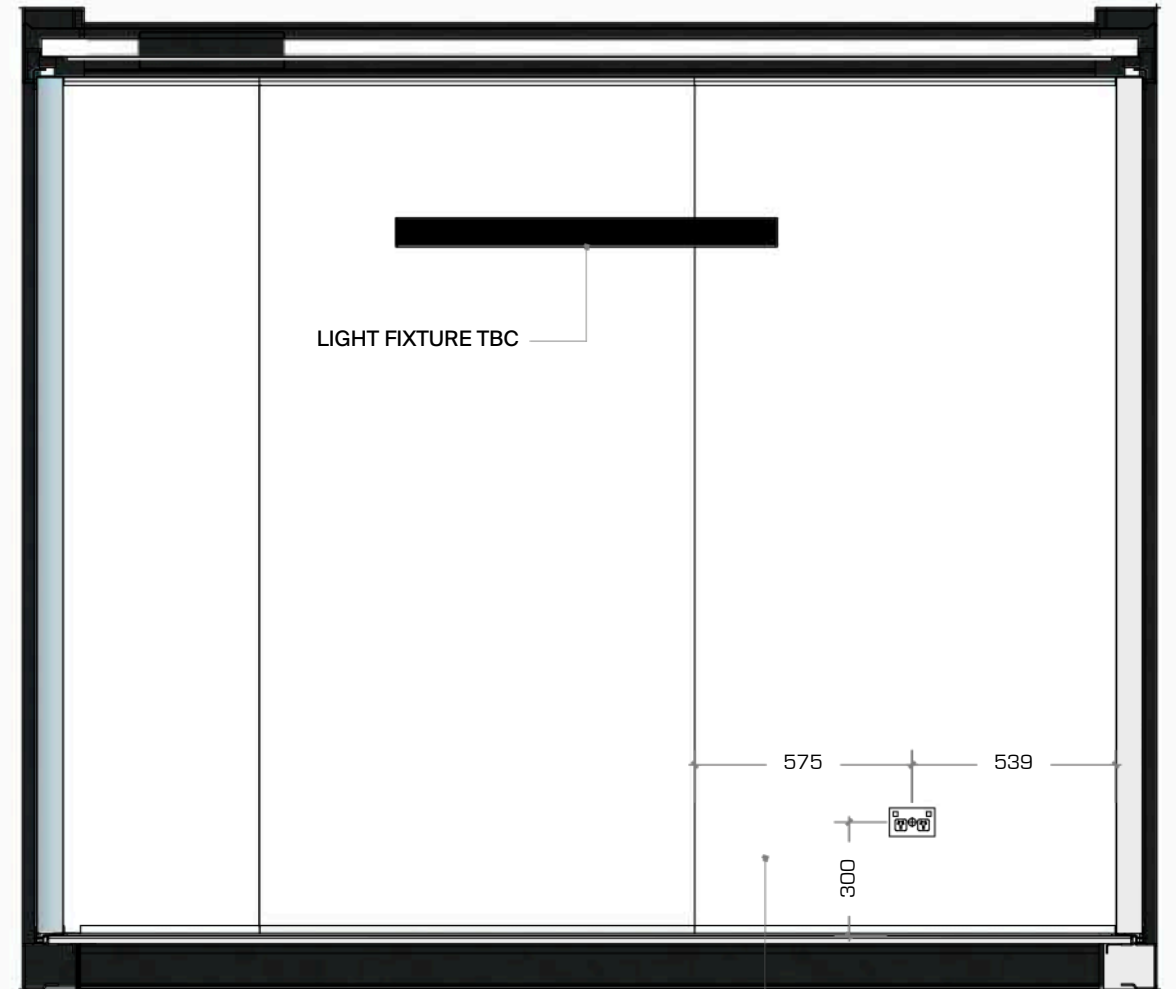

3 RHS WALL - INTERNAL
1:20 at A3

STANDARD WALL PANEL WITH POWER POINT