

NEW 3 X 3M PORTABLE BUILDING
BLACK FRAME - SPTU220029 | BRAND NEW

Purchase Price - \$27,500 + GST

Hire Price - please enquire

Pricing excludes delivery - quoted on request



Building Inclusions:



9 sqm (3m x 3m)



1x 2200mm double-glazed ranch slider door



1x 1500mm double-glazed double awning window



Corten steel, zinc galvanised, two pac paint finished exterior painted in Grey Friars



Internal walls are lined in birch ply, ceiling is lined with acoustic panels for sound proofing



Grey carpet tiles



Insulated with fire retardant rock wall (72 mm walls, 100mm floor and ceiling)



5x 10-amp standard twin power outlets, external C-Form 32amp connection, switchboard



2x black 60 W LED wall lights, 1x exterior security light

Introducing our newest high-spec transportable sleepout or home office. At 9sqm, it is perfectly sized to comfortably fit a queen-sized bed and drawers, or to arrange as a versatile office space.

Fully insulated to ensure warmth in winter and coolness in summer, it features ply wall panels for a stylish and durable interior finish, and acoustic panels on the roof to provide added comfort and noise reduction. Soft LED lights create a pleasant and efficient lighting environment, while double-glazed windows enhance thermal efficiency and sound insulation.

Exterior security lighting adds an extra layer of safety and convenience. Ideal for those needing extra space for guests, a quiet home office, or a personal retreat.

Additional inclusions:

- Electrical WOF - 4 years, issued prior to delivery.
- Sales multi-part new building warranty included with this building

Exclusions:

Delivery and installation, adaptations, site or groundworks, and joining kit if connecting buildings. Please enquire for a quote.

Pre-purchase inspection:

We encourage inspections of all our buildings before lease or purchase, please call us to make an appointment.



**NEW 3 X 3M PORTABLE BUILDING
BLACK FRAME - SPTU220029 | BRAND NEW**

Purchase Price - \$27,500 + GST







Hire Price - please enquire

Pricing excludes delivery - quoted on request

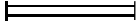

Images below for illustrative purposes - the building does not include furniture



-  DOUBLE POWER POINT
(300MM ABOVE FLOOR LEVEL
UNLESS OTHERWISE STATED)
-  LIGHT SWITCH
-  LED STRIP LIGHT
-  300MM CIRCULAR LED CEILING LIGHT
(IP65 IN BATHROOM AREA)
-  MAIN SWITCHBOARD
-  32A CEE 3P CONNECTION
-  EXTERNAL LIGHTING

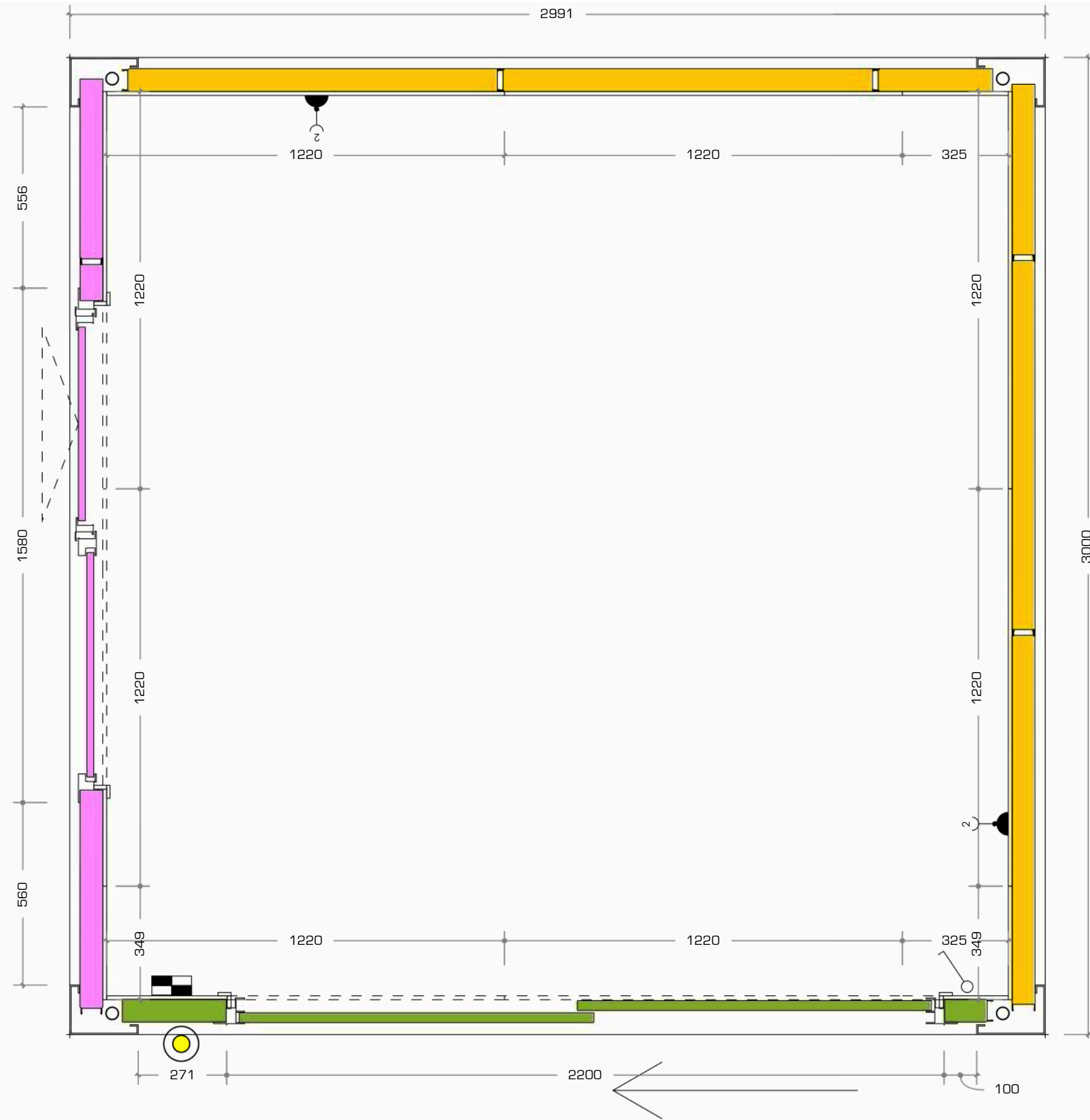

1 FLOOR PLAN
1:15 at A3



1 FRONT ELEVATION
1:30 at A3

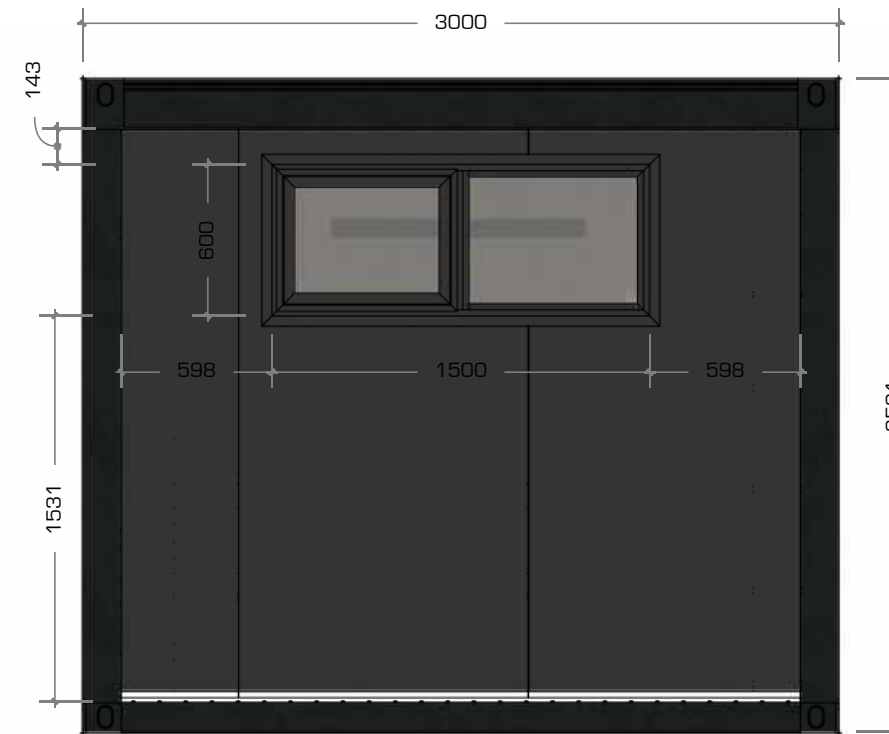

2 LHS ELEVATION
1:30 at A3

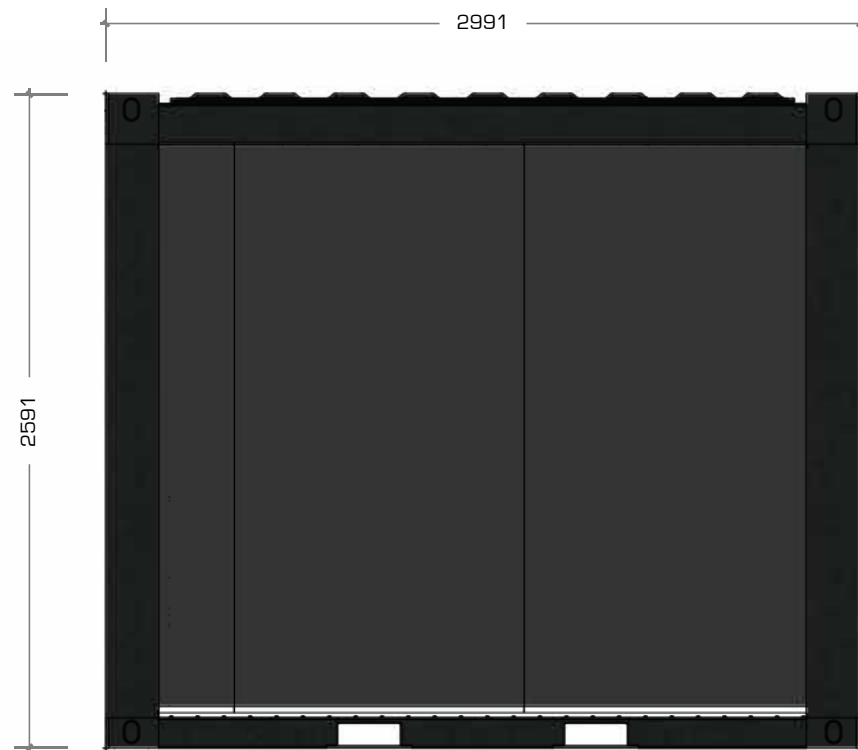

3 BACK ELEVATION
1:30 at A3

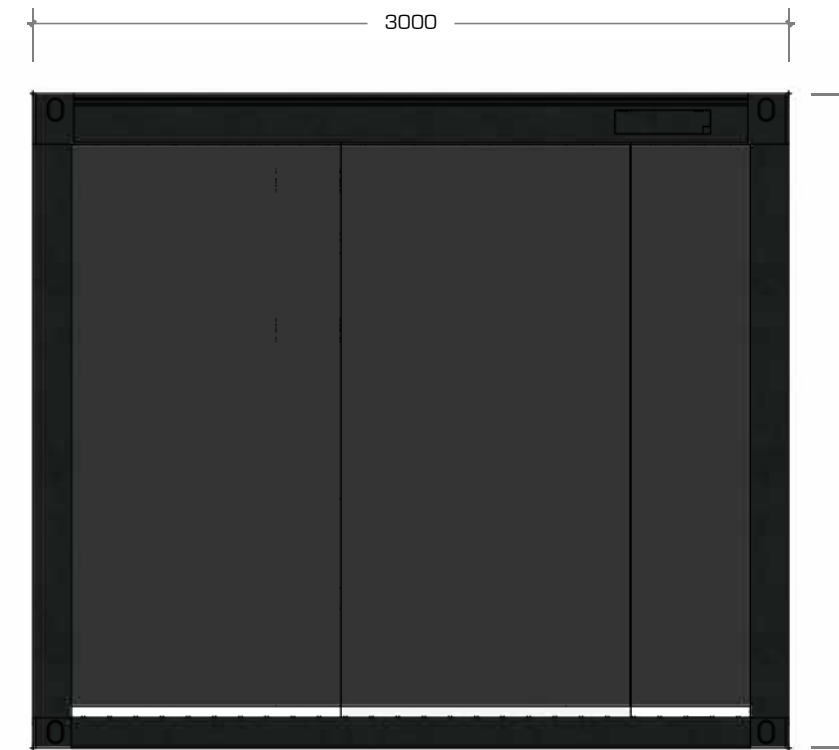

4 RHS ELEVATION
1:30 at A3

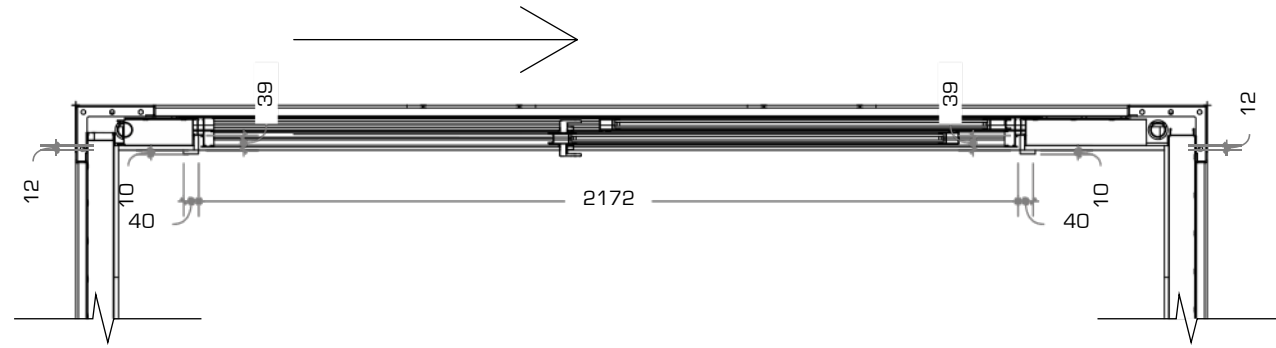

2 FRONT WALL - SECTION
1:20 at A3

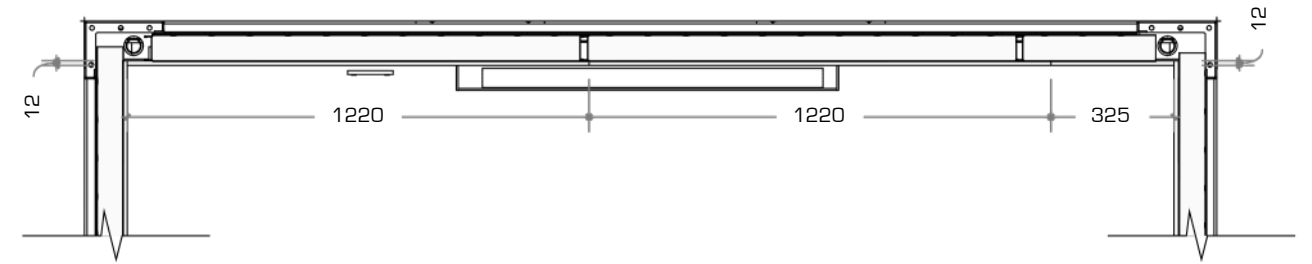

4 BACK WALL - SECTION
1:20 at A3

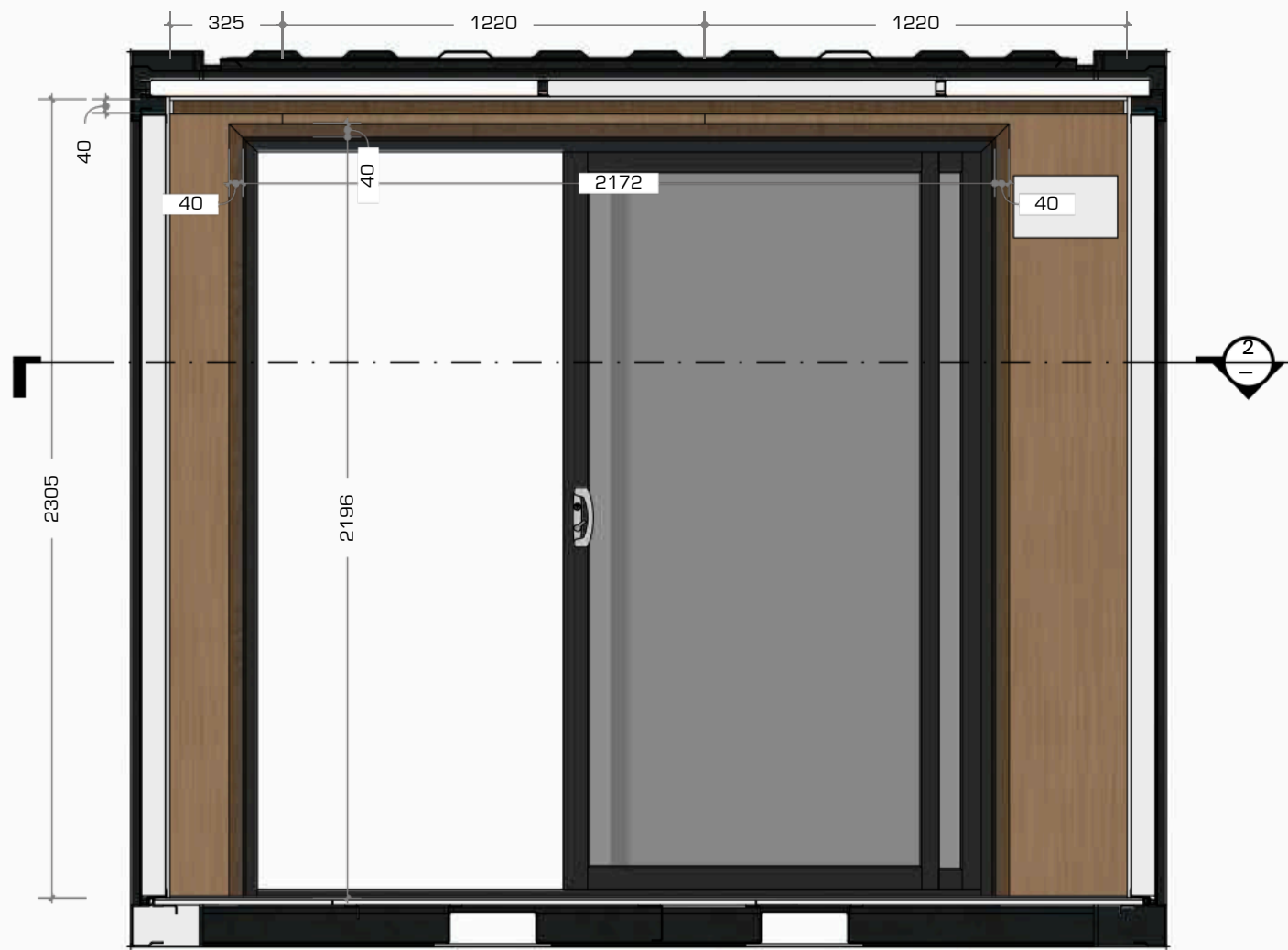

1 FRONT WALL - INTERNAL
1:20 at A3

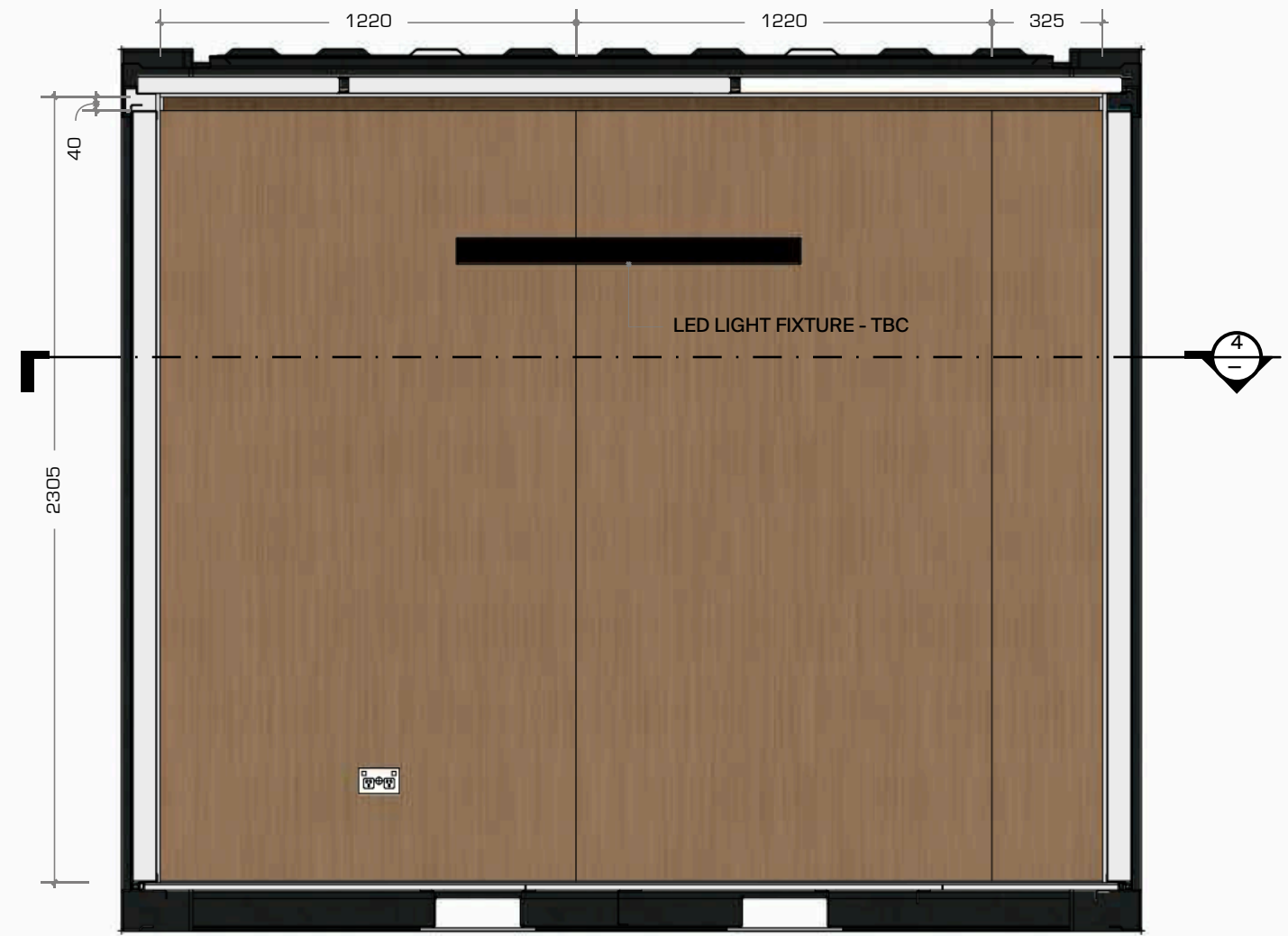

3 BACK WALL - INTERNAL
1:20 at A3

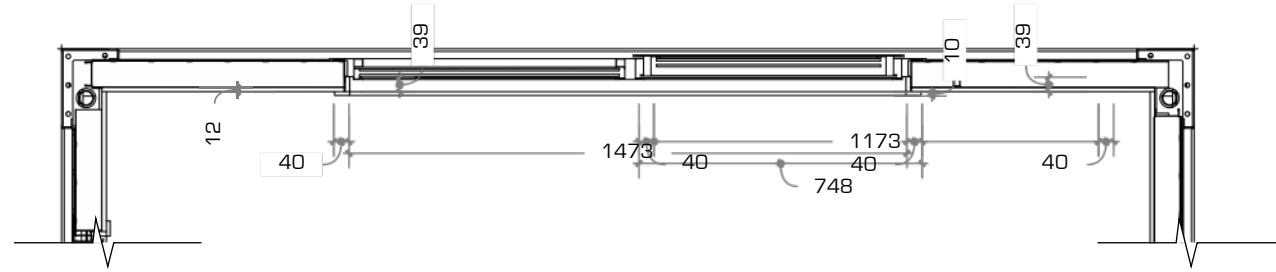

2 LHS WALL - SECTION
1:20 at A3

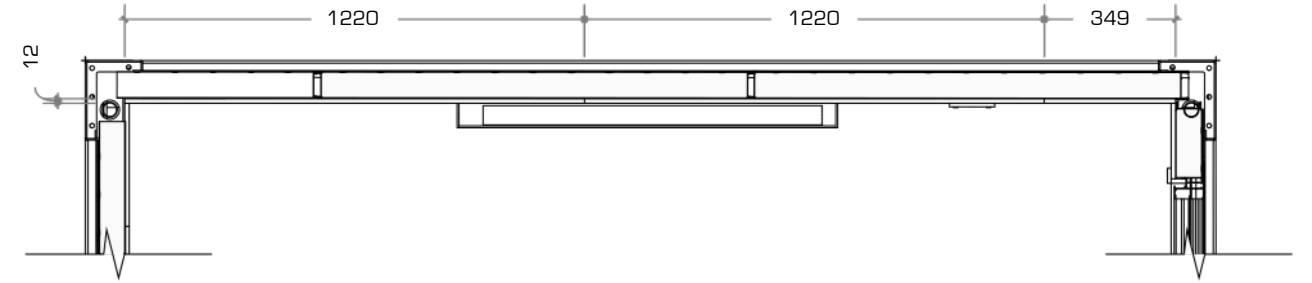

4 RHS WALL - SECTION
1:20 at A3

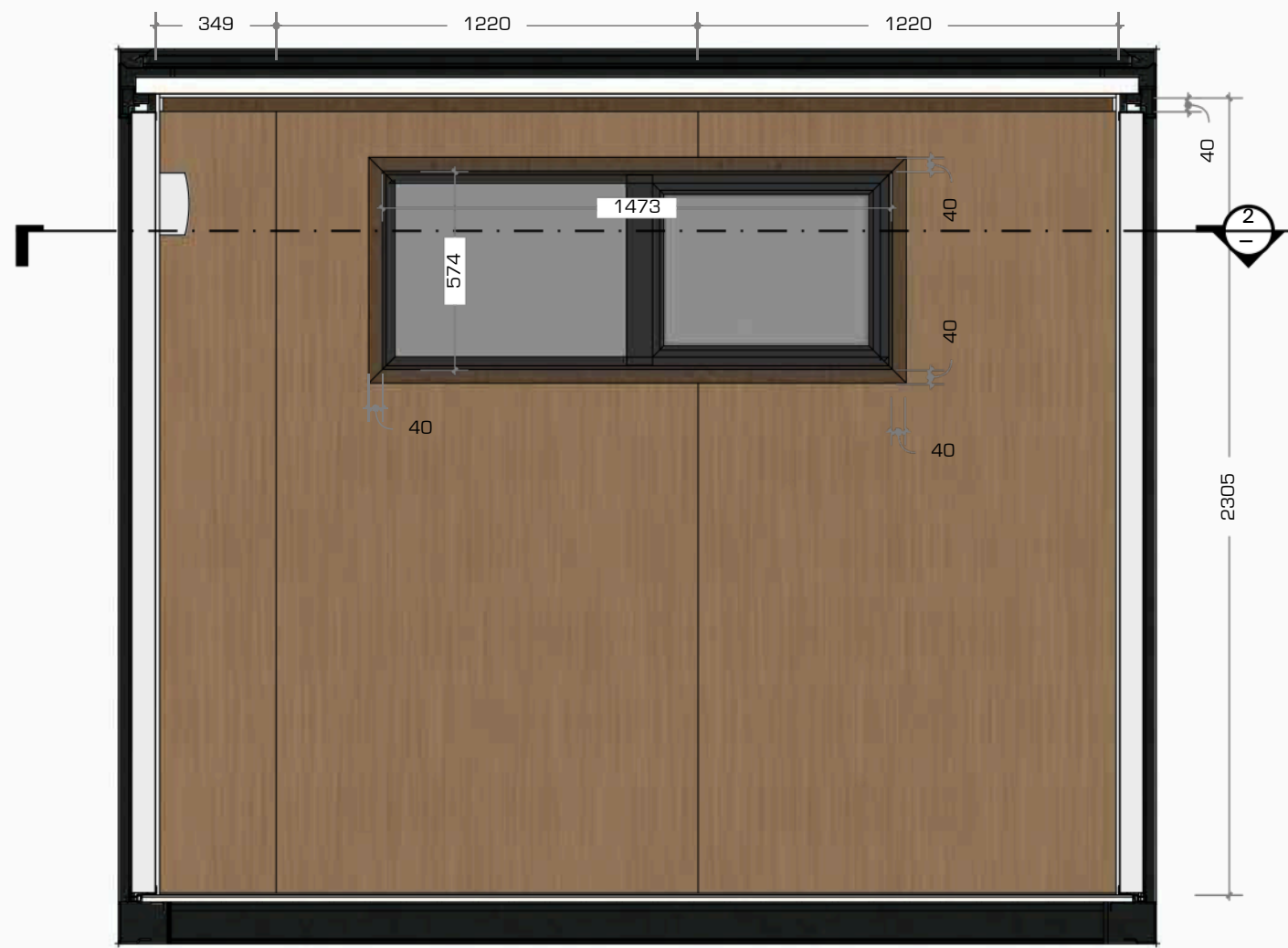

1 LHS WALL - INTERNAL
1:20 at A3

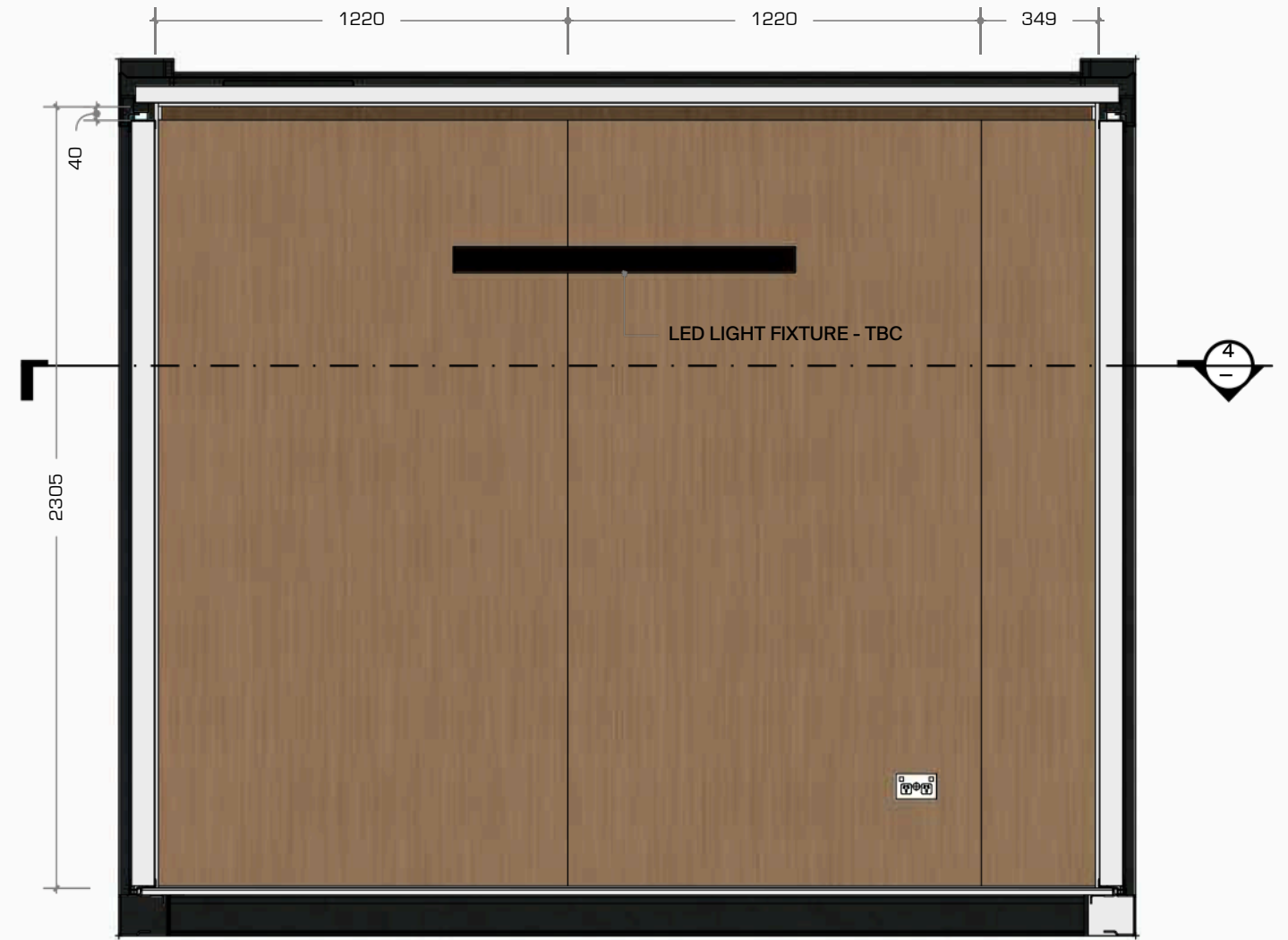

3 RHS WALL - INTERNAL
1:20 at A3

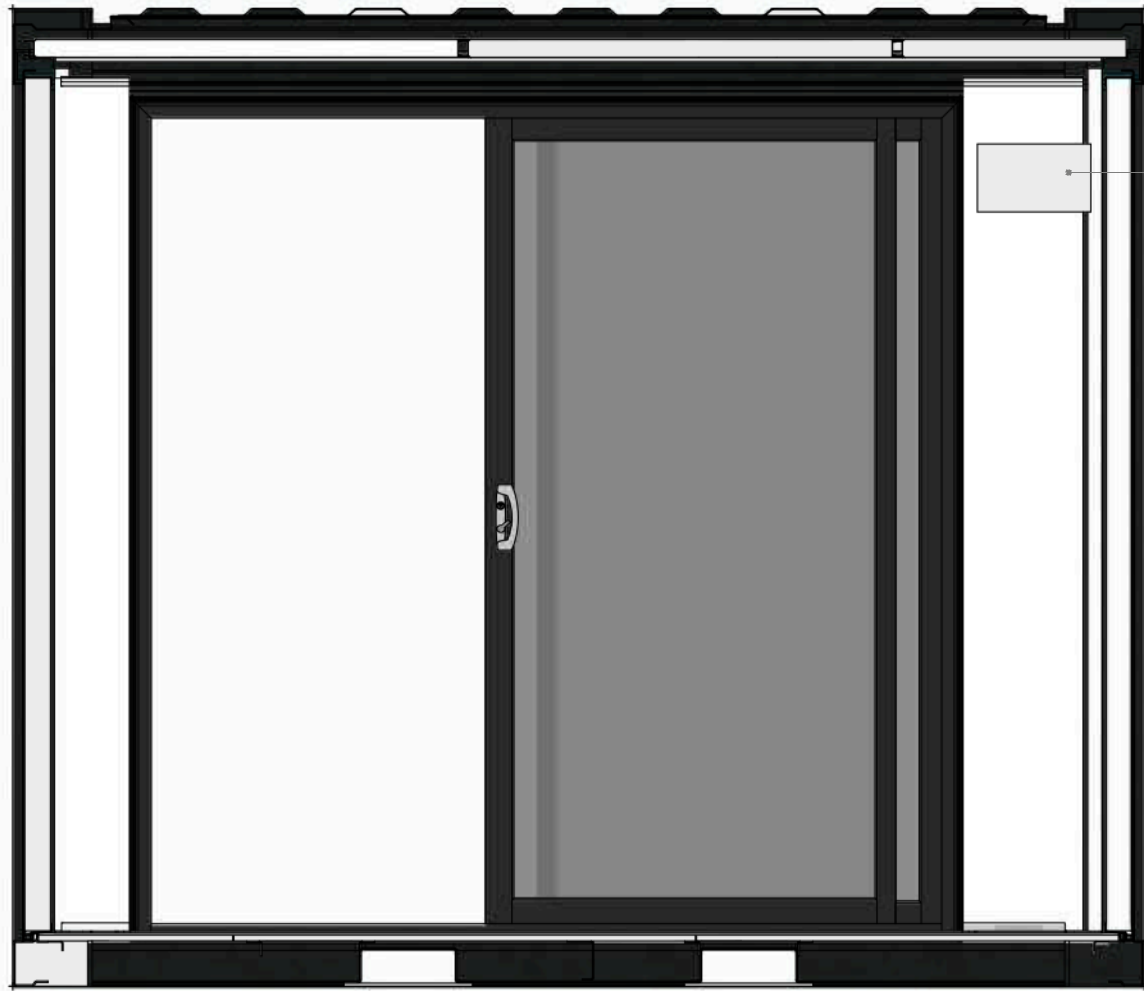

DB CENTRED
IN WALL PANEL
CTR 1995MM FROM FFL

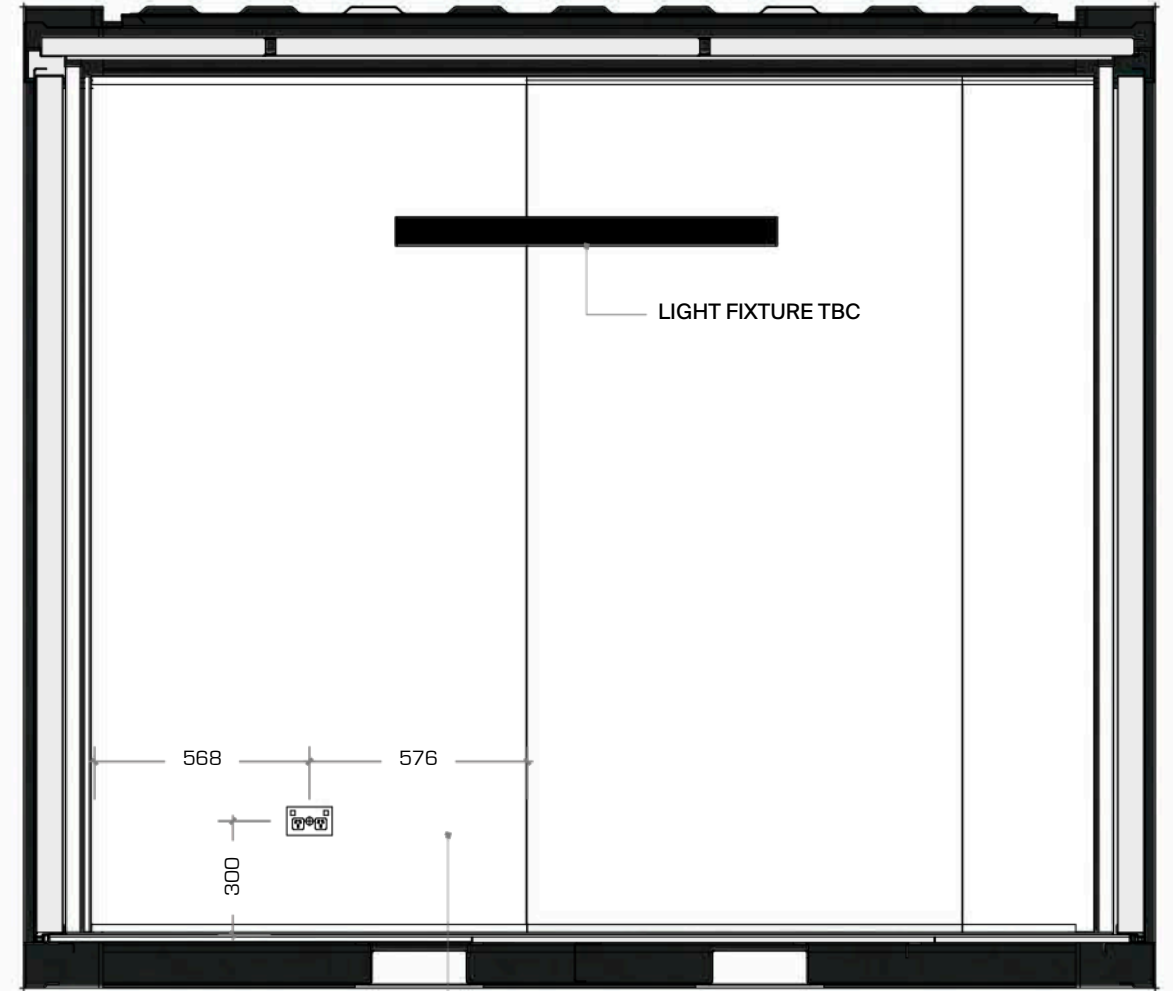

LIGHT FIXTURE TBC

568 576
300

STANDARD WALL PANEL WITH POWER POINT

1 FRONT WALL - INTERNAL
1:20 at A3

3 BACK WALL - INTERNAL
1:20 at A3

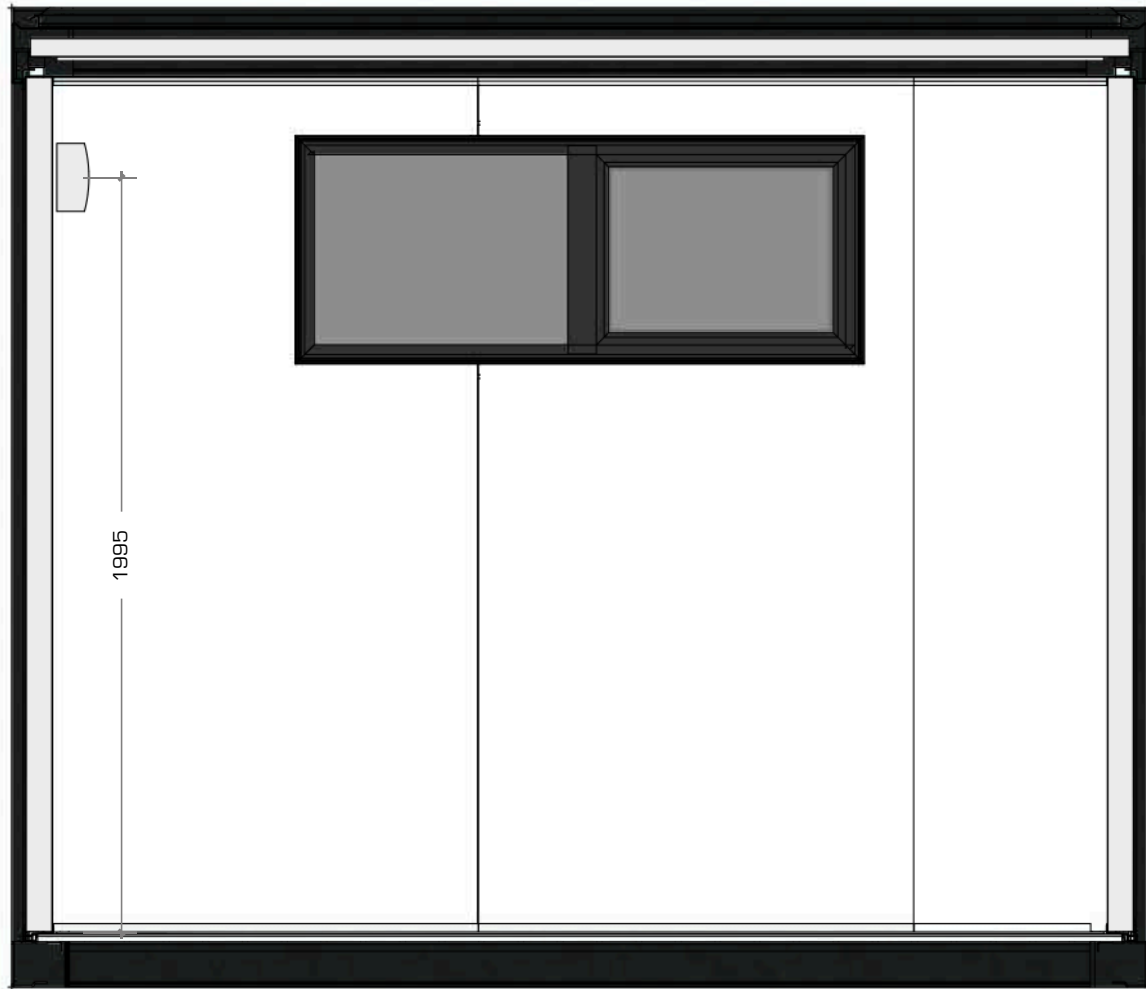

1 LHS WALL - INTERNAL
1:20 at A3

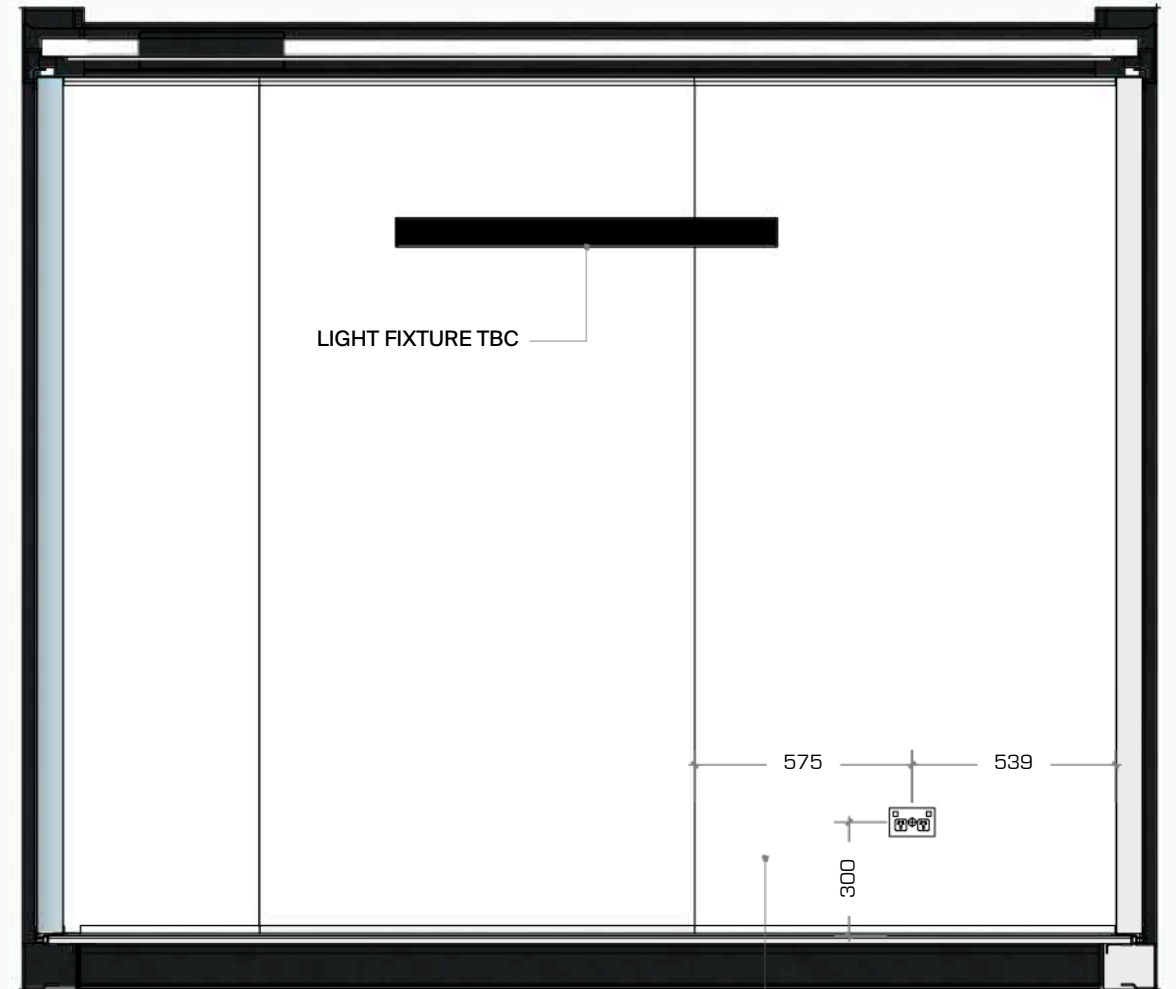

3 RHS WALL - INTERNAL
1:20 at A3